

Producer Register Ltd



PRI

WEEE2 – Definition and Understanding of the 6 Categories (15.08.2018)

Dominic Henry

14.12.17



Content

Objective	3
Definition of the 6 Categories.....	4
EEE measurement methodology and examples.....	6
Decision tree for categorization.....	8
European WEEE Registers Network (EWRN).....	9



Objective

The European Commission published on 4th of July 2012 Directive 2012/19/EU of the European Parliament and of the Council (“WEEE2”), regarding waste from electrical and electronic equipment (“EEE”).

From 15th of August 2018 all EEE shall be classified within the 6 categories set out in Annex III of WEEE2. For the allocation of EEE to three of the 6 categories it is necessary to know their external dimensions. This may cause additional work for producers who have to deal with the categorisation.

Therefore, this document provides guidance for and clarification of the definition of the categories, examples of misinterpretation, dimensions and measurement of (W)EEE.

Definition of 6 Categories

Category 1	Temperature exchange equipment (TEE)
Definition	Temperature exchange equipment is electrical and electronic equipment (“EEE”) with internal circuits where substances <u>other than water</u> – e.g. gas, oil, refrigerant or a secondary fluid - are used for the purpose of cooling and/or heating and/or dehumidifying.
Some examples from WEEE2 Directive / EWRN	Refrigerators, Freezers, Equipment which automatically deliver cold products, Air-conditioning equipment, Dehumidifying equipment, Heat pumps, Radiators containing oil and other temperature exchange equipment using fluids other than water for the temperature exchange.
Misinterpretations	EEE that is NOT in category 1: Ventilation equipment (e.g. fan, hot-air blower, fan coils etc.), infrared equipment, or water radiators, and in general all equipment using water without additives or refrigerants for temperature exchange

Definition of 6 Categories

Category 2	Screens, monitors, and equipment containing screens having a surface greater than 100 cm²
Definition	<p>Screens and monitors are EEE intended to provide images and information on an electronic display - <i>regardless of its dimension</i> - such as cathode ray tubes (CRT), liquid crystal displays (LCD), light-emitting diode (LED) displays or other kind of electronic displays.</p> <p>Additionally WEEE2 includes under category 2 other equipment containing screens having a surface greater than 100 cm². However, WEEE2 FAQ¹ clarify that not every equipment containing a screen greater than 100 cm² falls under category 2. Only EEE with a screen-surface greater than 100 cm² and whose intended usage focus is displaying images or information on a screen is allocated to category 2. Equipment such as Laptops, Notebooks, Tablets, eBook/eReaders with a screen surface greater than 100 cm² shall be considered under category 2, but not equipment like washing machines, refrigerators, printers, mobile phones (smartphones, phablets etc.), even if they have a screen surface greater than 100 cm², because their intended usage is not displaying information on a screen.</p>
Some examples from WEEE2 Directive / EWRN	Screens, Televisions, LCD photo frames, Monitors, Laptops, Notebooks, Tablets, eBook/eReaders
Misinterpretations	<p>EEE that is NOT in category 2:</p> <p>a) All small IT equipment, such as mobile phones (smartphones, phablets etc.), GPS and navigation equipment, pocket calculators, telephones etc. (such EEE is allocated to category 6).</p> <p>b) EEE that may contain screens with surfaces greater than 100 cm², such as some refrigerators, automated teller machines, body care equipment, industrial machinery, medical devices, printers, photocopier etc. temperature exchange</p>

Definition of 6 Categories

Category 3	Lamps
Definition	Lamps in every size are "equipment for the generation of light", which means electrical light sources (including LED lamps but not LED luminaires) which can be installed or exchanged by the end-user in specific electric and electronic devices such as luminaires, projectors, solariums etc.
Some examples from WEEE2 Directive / EWRN	Straight fluorescent lamps, Compact fluorescent lamps, Fluorescent lamps, High intensity discharge lamps - including pressure sodium lamps and metal halide lamps, Low pressure sodium lamps, LED lamps.
Misinterpretations	<p>EEE that is NOT in category 3:</p> <p>Luminaires²: an apparatus which distributes, filters or transforms the light transmitted from one or more lamps and which includes all the parts necessary for supporting, fixing and protecting the lamps and, where necessary, circuit auxiliaries together with the means for connecting them to the electric supply.</p> <p>Luminaires are allocated to category 4 or 5. Are luminaires with fixed lamps (that cannot be removed without damaging the unit) also to be considered as luminaires?</p>

^[2] The words "lamp" and "luminaire" are often mixed up

Definition of 6 Categories

Category 4	Large equipment (any external dimension more than 50 cm)
Definition	<p>EEE that is not allocated to categories 1, 2 or 3. Any external dimension is more than 50 cm. The external dimensions of the equipment needs to be measured in a status ready for use. (For correct measurement of EEE see “EEE measurement methodology” on slide 11.)</p>
Some examples from WEEE2 Directive / EWRN	<p>Washing machines, Clothes dryers, Dish washing machines, Cookers, Electric stoves, Electric hot plates, Luminaires, Equipment reproducing sound or images, Musical equipment (excluding pipe organs installed in churches), Appliances for knitting and weaving, Large computer-mainframes, Large printing machines, Copying equipment, Large coin slot machines, Large medical devices, Large monitoring and control instruments, Large appliances which automatically deliver products and money, Photovoltaic panels. Household appliances; IT and telecommunication equipment; consumer equipment; luminaires; equipment reproducing sound or images, musical equipment; electrical and electronic tools; toys, leisure and sports equipment; monitoring and control instruments; automatic dispensers; equipment for the generation of electric currents.</p> <p>This category does not include equipment included in categories 1 to 3.</p>
Misinterpretations	<p>EEE that is NOT in category 4:</p> <p>Refrigerated vending machines (category 1), large screens (category 2), large lamps (long fluorescent tubes) (category 3) etc.</p>

Definition of 6 Categories

Category 5	Small equipment (no external dimension more than 50 cm)
Definition	<p>EEE that is not allocated to categories 1, 2, 3, 4 or 6. No external dimension is more than 50 cm.</p> <p>The determination of dimensions follows the definition provided for category 4 above. If then the largest outer dimension is 50 cm or less and it's <u>not</u> IT or telecommunication equipment it meets the definition of category 5.</p>
Some examples from WEEE2 Directive / EWRN	<p>Vacuum cleaners, Carpet sweepers, Appliances for sewing, Luminaires, Microwaves, Ventilation equipment, Irons, Toasters, Electric knives, Electric kettles, Clocks and Watches, Electric shavers, Scales, Appliances for hair and body care, Radio sets, Digital cameras, Video cameras, Video recorders, Hi-fi equipment, Musical instruments, Equipment reproducing sound or images, Electrical and electronic toys, Sports equipment, Computers for biking, diving, running, rowing, etc., Smoke detectors, Heating regulators, Thermostats, Small Electrical and electronic tools, Small medical devices, Small Monitoring and control instruments, Small Appliances which automatically deliver products, Small equipment with integrated photovoltaic panels. Household appliances; consumer equipment; luminaires; equipment reproducing sound or images, musical equipment; electrical and electronic tools; toys, leisure and sports equipment; medical devices; monitoring and control instruments; automatic dispensers; equipment for the generation of electric currents.</p> <p>This category does not include equipment included in categories 1 to 3 and 6</p>
Misinterpretations	<p>EEE that is NOT in category 5:</p> <p>Small IT equipment with external dimension less than 50 cm (mobile phones (e.g., smartphones, phablets etc.), routers, printers, GPS and navigation equipment etc.) is allocated to category</p>

Definition of 6 Categories

Category 6	Small IT and telecommunication equipment (no external dimension more than 50 cm)
Definition	<p>EEE that is not allocated to categories 1, 2, 3, 4 or 5.</p> <p>Information equipment is equipment that can be used for collecting, transmitting, processing, storing and showing information. Telecommunication equipment is equipment designed to transmit signals – voice, video and data – electronically over a certain distance.</p> <p>The determination of dimensions is the same as for category 5. If then the equipment is IT or telecommunication equipment it meets the definition of category 6</p>
Some examples from WEEE2 Directive / EWRN	Mobile phones (smartphones, phablets etc.), GPS and navigation equipment, Pocket calculators, Routers, Personal computers, Printers, Telephones.
Misinterpretations	<p>EEE that is NOT in category 6:</p> <p>Small equipment that is not IT and telecommunication equipment (e.g. mp3 players etc.), large IT equipment (large printers) and IT equipment with screens greater than 100 cm² (laptops, tablets, eBook-/e-Readers etc.) that are in category</p>

The European Commission addresses some measurement problems in the WEEE2 FAQ⁴ document advising to draw a box around the EEE. However, this approach, although simple, may cause misinterpretations (see image on the right, where different boxes may lead to different external dimensions).

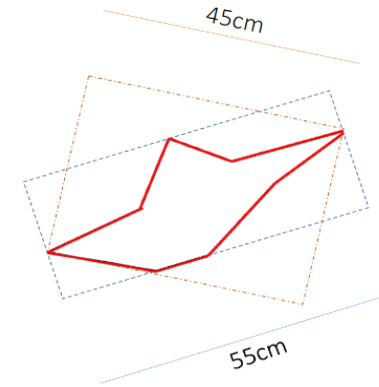

Therefore, EWRN recommends the following measurement methodology:

As a general rule EWRN proposes that the external dimensions of an EEE product shall be measured **in a ready for use status** but **without parts and accessories**⁵ such as hoses, tubes and cables. **Power cables**, fixed or detachable, are also not measured with the EEE. If the EEE has **fixed retractile or foldable parts** (e.g. antennas or articulated arms) it shall be adjusted to its most compact form in order to minimize the impact on the measurement.

Example: radio with long retractable antenna, household water kettle with long flexible cable. These EEE are small equipment in category 5 if the EEE is not larger than 50 cm, even when the extracted antenna or flexible power cable would be 100 cm long.

⁴Frequently Asked Questions on Directive 2012/19/EU, Q 5.2, page 15 regarding Article 5 (2)(c) WEEE2 for very small equipment up to 25 cm

⁵If such parts or accessories are EEE themselves they require to be measured individually

How to gather dimension-data?

(1) Manufacturer's dimensions are available

EEE dimensions provided in manufacturer's specifications (for **rectangular equipment**: *height, width and depth*; for **round equipment**: *diameter*) are generally sufficient to determine whether the EEE is large or small equipment. Packaging dimensions shall not be considered.

(1) Manufacturer's dimensions are not available or helpful

The largest external dimension of the EEE can be found using the recommended measurement methodology of EWRN, above. If the largest dimension is more than 50 cm the EEE is **large equipment**. If the largest dimension is less than or equal 50 cm the EEE is **small equipment**. For the majority of EEE this procedure provides the desired dimensions easily. In case of **rectangular equipment** the *largest height, width or depth of the EEE is relevant*. For **round equipment** the *largest diameter* is applicable.

Measurement Examples



Tower PC
External dimension:
the larger value of H or W

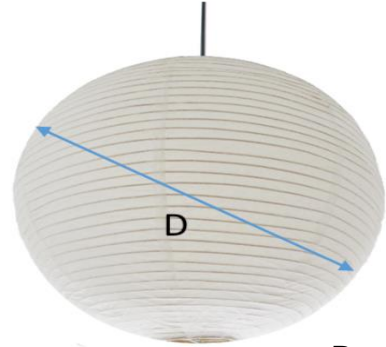

Round equipment
External dimension:
diameter D



LED colour organ
External dimension:
value H

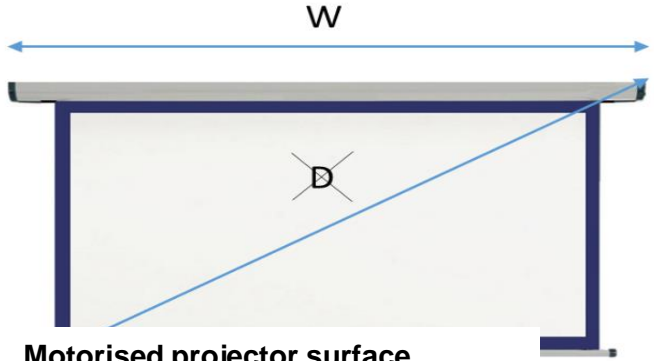

Motorised projector surface
External dimension:
value of W, (not value D)

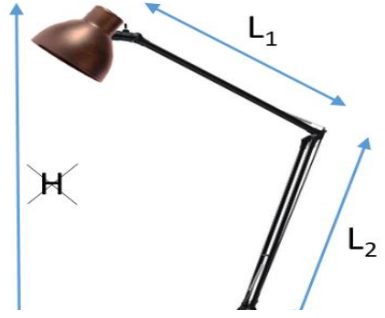

Luminaire (articulated)
External dimension:
the larger value of L_1 or L_2 ,
(not value H)

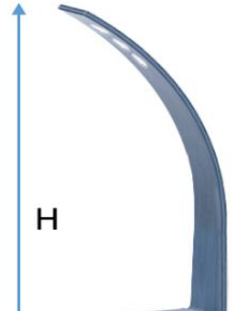

Luminaire (not flexible)
External dimension:
value of H



Vacuum cleaner
External dimension:
value of H (without hose and
floor head)

Decision Tree for Categorization

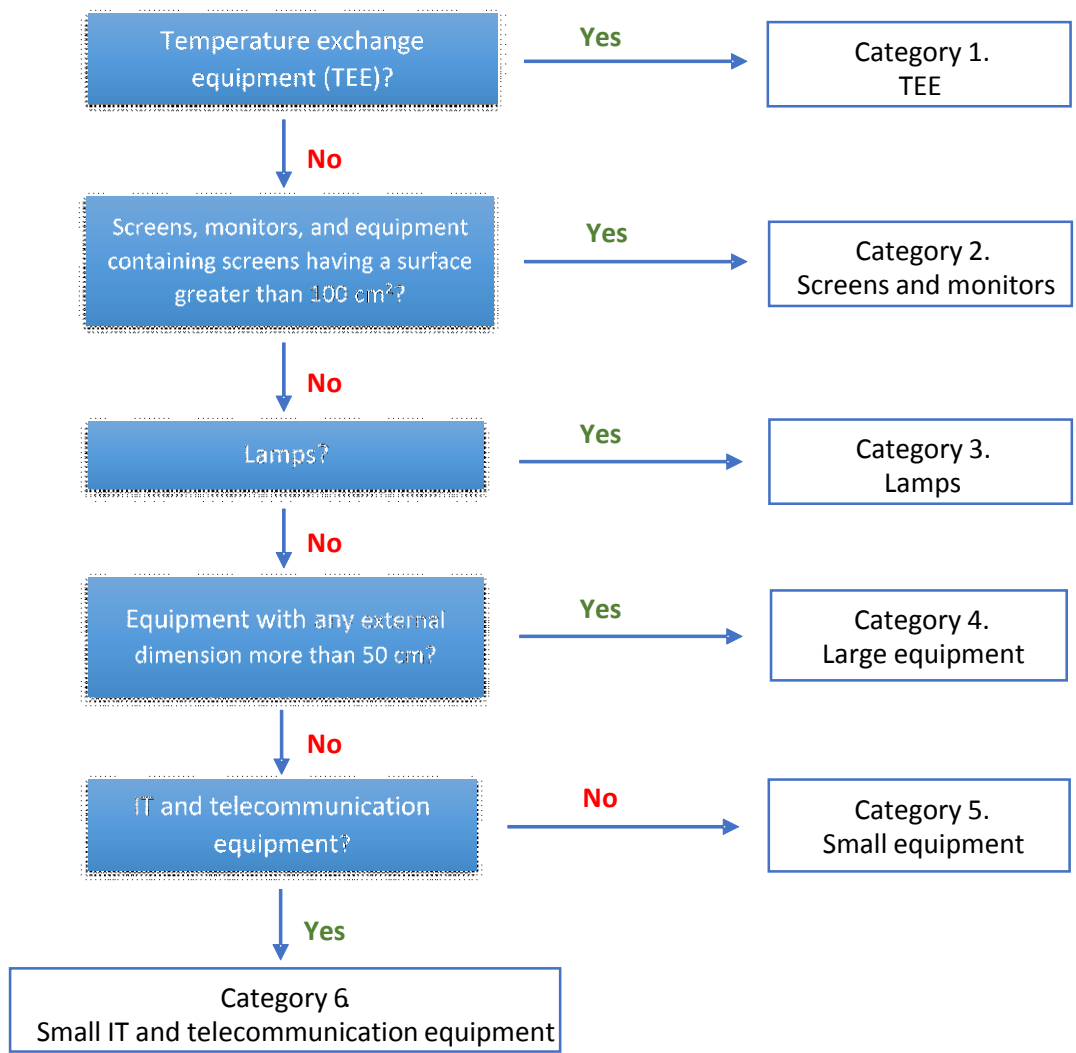

European WEEE Registers Network (EWRN)

EWRN is an independent network of national registers at the heart of the national implementation of Directive 2012/19/EU (“WEEE2”) in the respective EU Member States.

Those responsible for managing the national registers are working together at EWRN as experts regarding electrical and electronic equipment (“EEE”) and its proper treatment.

EWRNs primary objectives includes promoting a harmonised approach to registration, reporting and scoping issues across the Member States. This includes harmonised interpretation of the WEEE2.

Facts:

- EWRN was established in November 2006
- 17-18 National Registers core attendance and participation
- No involvement in or any relation to recycling

Aim is to assist producers by

- Harmonising registration and reporting procedures
- Securing fair and equal competition by harmonising scoping decisions
- Identifying and enabling prosecution of free-riders, to ensure equitable cost burden among all those with responsibilities
- Detecting and easing producer problems subject to WEEE2 and its enforcement



Thank you very much for your attention

Dominic.Henry@producerregister.ie

01-5522606